

鎢鋼 2刃立銑刀

TUNGSTEN CARBIDE 2-FLUTE END MILL

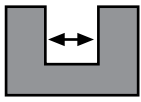

$d \leq 3$ -0.005 ~ -0.028
 $3 < d \leq 6$ -0.015 ~ -0.038
 $6 < d \leq 18$ -0.020 ~ -0.047
 $18 < d$ -0.020 ~ -0.053

- 超細微粒碳化鎢材質
- Micro-Grain Tungsten Carbide

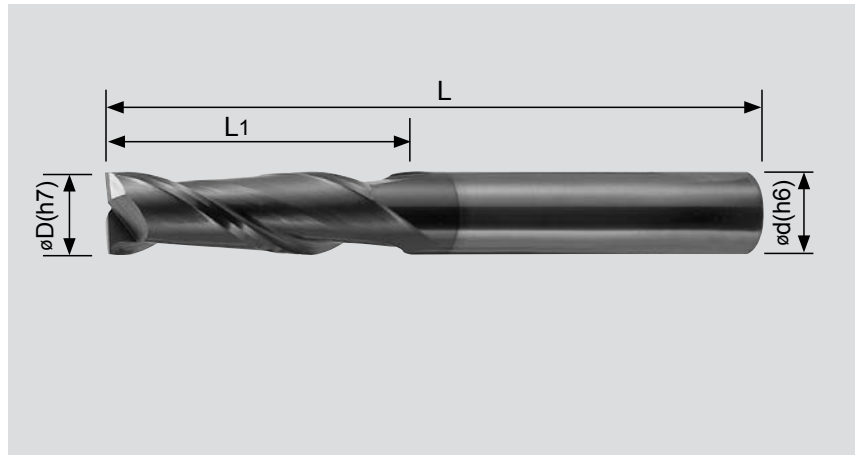

適合材質：

碳素鋼、模具鋼、合金鋼、工具鋼、鑄鐵、不鏽鋼、熱處理鋼、焊補鋼料。

Applicable materials:

Carbon steel, mold steel, alloy steel, tool steel, stainless steel, heat-treated steel, welded steel, cast iron.

單位/Unit : mm

型號 EDP NO.	刃徑 D Flute Dia.	刃長 L1 Length of Cut	全長 L Overall Length	柄徑 d Shank Diameter	刃數 Flute Number	AK45	AK925	PK66
2E-D1.0L50	1.0	3.0	50	4.0	2	●	●	●
2E-D1.5L50	1.5	4.0	50	4.0	2	●	●	●
2E-D2.0L50	2.0	6.0	50	4.0	2	●	●	●
2E-D3.0L50	3.0	8.0	50	4.0	2	●	●	●
2E-D3.0L38	3.0	8.0	38	3.0	2	●	●	●
2E-D4.0L50	4.0	14.0	50	4.0	2	●	●	●
2E-D5.0L50	5.0	13.0	50	6.0	2	●	●	●
2E-D6.0L50	6.0	17.0	50	6.0	2	●	●	●
2E-D8.0L60	8.0	20.0	60	8.0	2	●	●	●
2E-D10.0L75	10.0	25.0	75	10.0	2	●	●	●
2E-D12.0L75	12.0	30.0	75	12.0	2	●	●	●
2E-D16.0L100	16.0	40.0	100	16.0	2	●	●	●
2E-D20.0L100	20.0	45.0	100	20.0	2	●	●	●
2EL-D2.0L75	2.0	15.0	75	4.0	2			●
2EL-D3.0L75	3.0	15.0	75	4.0	2			●
2EL-D3.0L100	3.0	15.0	100	3.0	2			●
2EL-D4.0L75	4.0	20.0	75	4.0	2			●
2EL-D4.0L100	4.0	20.0	100	4.0	2			●
2EL-D5.0L75	5.0	25.0	75	5.0	2			●
2EL-D5.0L100	5.0	25.0	100	5.0	2			●
2EL-D6.0L100	6.0	30.0	100	6.0	2			●
2EL-D8.0L100	8.0	35.0	100	8.0	2			●
2EL-D10.0L100	10.0	40.0	100	10.0	2			●
2EL-D12.0L100	12.0	50.0	100	12.0	2			●
2EL-D16.0L150	16.0	55.0	150	16.0	2			●
2EL-D20.0L150	20.0	60.0	150	20.0	2			●

註: 有●者表示有庫存
NOTE: ● means items in stock

切削條件表請參考第77頁