

全鎢鋼NC定位鑽頭

SOLID CARBIDE NC POSITIONING DRILL



鎢鋼材質 高硬度、耐磨耗，鑽頂角 90° 、 120° 。

Tungsten Carbide material, high hardness, high wear resistance, point angle 90° or 120°

適合材質：

銅一般鋼料、合金鋼、不鏽鋼、銅、鋁、鑄鐵。

Applicable materials:

General steel, alloy steel, stainless steel, copper, aluminum, cast iron.

全鎢鋼單頭NC 定位鑽頭

SOLID TUNGSTEN SINGLE END NC POSITIONING DRILL

型號 EDP NO.	β°	直徑 ϕD	刃長 L_2	全長 L	柄徑 ϕd
NSP - 9003	90°	3.0	8	38	3.0
NSP - 9004	90°	4.0	10	40	4.0
NSP - 9005	90°	5.0	15	50	5.0
NSP - 9006	90°	6.0	15	50	6.0
NSP - 9008	90°	8.0	20	60	8.0
NSP - 9010	90°	10.0	22	75	10.0
NSP - 9012	90°	12.0	20	75	12.0
NSP - 9016	90°	16.0	25	100	16.0
NSP - 9020	90°	20.0	40	100	20.0
NSP - 12003	120°	3.0	8	38	3.0
NSP - 12004	120°	4.0	10	40	4.0
NSP - 12005	120°	5.0	15	50	5.0
NSP - 12006	120°	6.0	15	50	6.0
NSP - 12008	120°	8.0	20	60	8.0
NSP - 12010	120°	10.0	22	75	10.0
NSP - 12012	120°	12.0	20	75	12.0
NSP - 12016	120°	16.0	25	100	16.0
NSP - 12020	120°	20.0	40	100	20.0

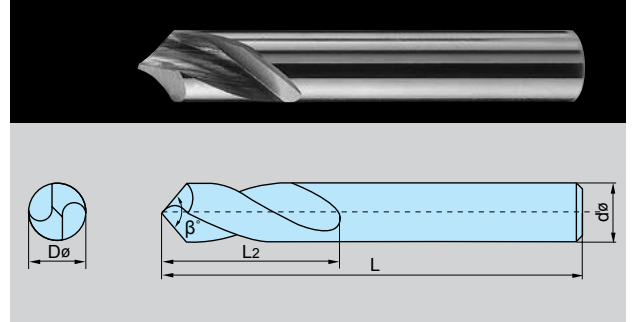

全鎢鋼單頭NC 定位鑽頭

SOLID TUNGSTEN SINGLE END NC POSITIONING DRILL

型號 EDP NO.	β°	A°	直徑 ϕD	刃徑 ϕD_s	刃長 L_2	全長 L	柄徑 ϕd
PNSP - 03	90°	118°	3.0	1.5	8	38	3.0
PNSP - 04	90°	118°	4.0	2.0	10	40	4.0
PNSP - 05	90°	118°	5.0	2.0	15	50	5.0
PNSP - 06	90°	118°	6.0	2.5	15	50	6.0
PNSP - 08	90°	118°	8.0	3.0	20	60	8.0
PNSP - 10	90°	118°	10.0	4.0	22	75	10.0
PNSP - 12	90°	118°	12.0	5.0	25	75	12.0
PNSP - 16	90°	118°	16.0	7.0	40	100	16.0

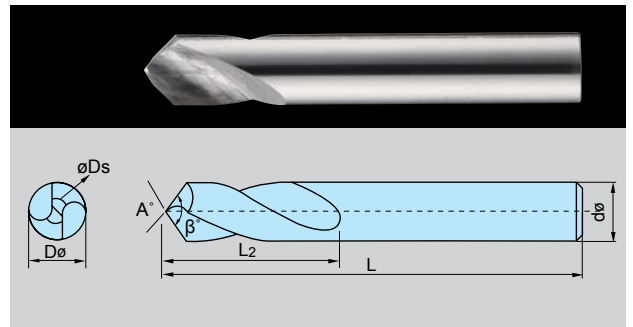

全鎢鋼單頭NC 定位鑽頭

SOLID TUNGSTEN SINGLE END NC POSITIONING DRILL

型號 EDP NO.	β°	A°	直徑 ϕD	刃徑 ϕD_s	刃長 L_2	全長 L	柄徑 ϕd
HNSP - 03	90°	140°	3.0	1.5	8	38	3.0
HNSP - 04	90°	140°	4.0	2.0	10	40	4.0
HNSP - 05	90°	140°	5.0	2.0	15	50	5.0
HNSP - 06	90°	140°	6.0	2.5	15	50	6.0
HNSP - 08	90°	140°	8.0	3.0	20	60	8.0
HNSP - 10	90°	140°	10.0	4.0	22	75	10.0
HNSP - 12	90°	140°	12.0	5.0	25	75	12.0
HNSP - 16	90°	140°	16.0	7.0	40	100	16.0

